

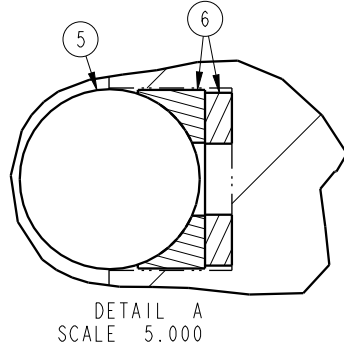

NO.	QTY.	DESCRIPTION	1			2		
			15-2105-03-X	15-2109-04-X	15-2113-04-X	STANDARD SEAL KIT	FLUOROCARBON SEAL KIT	SPRING KIT
1	1	BUTTON HEAD CAP SCREW	21-4110-01	21-4100-09	21-4100-39	NO	NO	NO
2	1	WIPER, ROD (FLUOROCARBON)	39-0530-04	39-0530-01	39-0530-00	YES	YES	NO
3	1	BACK-UP RING, ROD	39-F540-00	39-F540-01	39-F540-02	YES	YES	NO
4	1	SEAL, ROD (STANDARD)	39-0100-38	39-0100-20	39-0110-46	YES	NO	NO
	1	SEAL, ROD (FLUOROCARBON)	39-0520-14	39-V100-20	39-V110-46	NO	YES	NO
5	1	BALL, ALLOY	23-6000-14	23-6000-11	23-6000-02	YES	YES	NO
6	1	BALL SEAT ASSEMBLY	90-1999-88	90-1999-89	90-1999-90	YES	YES	NO
7	1	BREATHER	92-0900-01	92-0900-01	92-0900-01	NO	NO	NO
8	2	O-RING, MANIFOLD (STANDARD)	39-0000-50	39-0000-50	39-0000-50	YES	NO	NO
	2	O-RING, MANIFOLD (FLUOROCARBON)	39-0510-22	39-0510-22	39-0510-22	NO	YES	NO
9	1	PLUNGER	81-5105-00	81-5109-01	81-5113-01	NO	NO	NO
10	1	SEAL, PLUNGER (STANDARD)	39-0100-36	39-0100-15	39-0110-27	YES	NO	NO
	1	SEAL, PLUNGER (FLUOROCARBON)	39-0520-10	39-0520-11	39-0520-12	NO	YES	NO
11	1	PIVOT BALL	23-6000-14	23-6000-11	23-6000-02	NO	NO	YES
12	1	PIVOT DISK	N/A	81-5909-01	81-5913-01	NO	NO	YES
13	1	SPRING GUIDE / PIVOT DISK	81-5905-01	N/A	N/A	NO	NO	NO
14	1	INNER SPRING	23-3100-08	23-3110-13	23-3130-09	NO	NO	YES
15	1	OUTER SPRING	23-3110-17	23-3130-08	23-3130-10	NO	NO	YES
16	1	O-RING, RETAINER (FLUOROCARBON)	39-V000-36	39-0510-31	39-V510-43	YES	YES	NO
17	1	RETAINER	81-4000-28	81-4000-29	81-4000-30	NO	NO	NO
N/A	N/A	SEAL KIT (STANDARD)	60-1501-30	60-1501-31	60-1501-32	INCLUDED IN KIT		
N/A	N/A	SEAL KIT (FLUOROCARBON)	6V-1501-30	6V-1501-31	6V-1501-32			
N/A	N/A	SPRING KIT	61-1503-05	61-1503-09	61-1503-13			

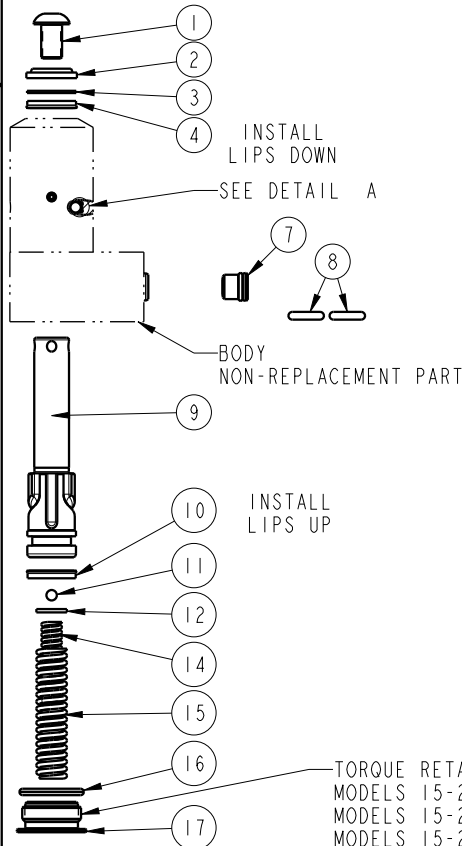

NOTES:
 1. APPLY LUBRICANT TO ALL SEALS PRIOR TO INSTALLATION.
 2. DO NOT USE SILICONE TYPE LUBRICANTS.
 3. SEAL KITS CONTAIN MANIFOLD MOUNT O-RINGS FOR BOTH BOTTOM FLANGE, (LARGE CROSS-SECTION), AND TOP FLANGE, (SMALL CROSS-SECTION), MODELS.
 ALSO AVAILABLE: IS-1500 INSTRUCTION SHEET

PARTS LIST	 VEKTEK, INC. 1334 E. SIXTH AVE. P.O. BOX 625 EMPORIA, KS. 66801 U.S.A.	
	PARTS LIST, SC, BF, VC, SA	
	SIZE A PL15124	REV D

D	5206	RELEASE	BDC	11/21/23
REV	IN ACCORDANCE WITH ECN	EFFECTIVE DATE	REVISED BY	DATE
DRW BY:	NPETERS	DRAWING STATUS: Released PRODUCTION APPROVED FOR RELEASED STATUS ONLY		
DATE:	5/17/21			